



US 20140353630A1

(19) **United States**
(12) **Patent Application Publication**
Baek et al.

(10) **Pub. No.: US 2014/0353630 A1**
(43) **Pub. Date: Dec. 4, 2014**

(54) **ORGANIC WHITE LIGHT EMITTING DISPLAY APPARATUS**

(52) **U.S. Cl.**
CPC **H01L 27/3211** (2013.01); **H01L 27/3262** (2013.01)

(71) Applicant: **Samsung Display Co., Ltd.**,
Yongin-City (KR)

USPC **257/40**

(72) Inventors: **Soo-Min Baek**, Yongin-City (KR);
Min-Woo Kim, Yongin-City (KR);
Il-Nam Kim, Yongin-City (KR); **Jae-Ik Lim**, Yongin-City (KR)

(57) **ABSTRACT**

(73) Assignee: **Samsung Display Co., Ltd.**,
Yongin-City (KR)

Disclosed is an organic white light emitting display apparatus. The organic white light emitting device includes a first substrate including a first sub-pixel area, a second sub-pixel area, a third sub-pixel area, and an organic light emitting device (OLED) that includes a first electrode, a second electrode, and an organic white light emitting layer interposed between the first and second electrodes, and emits whit light for respective sub-pixel areas, a second substrate including first, second, and third color filters of different colors formed on positions corresponding to the respective sub-pixel areas, the second substrate being arranged to face the first substrate, and a partition wall that is extended to an area between neighboring color filters among the color filters and partitions the sub-pixel areas, the partition wall being formed on the first substrate.

(21) Appl. No.: **14/222,417**

(22) Filed: **Mar. 21, 2014**

(30) **Foreign Application Priority Data**

May 31, 2013 (KR) 10-2013-0063075

Publication Classification

(51) **Int. Cl.**
H01L 27/32 (2006.01)

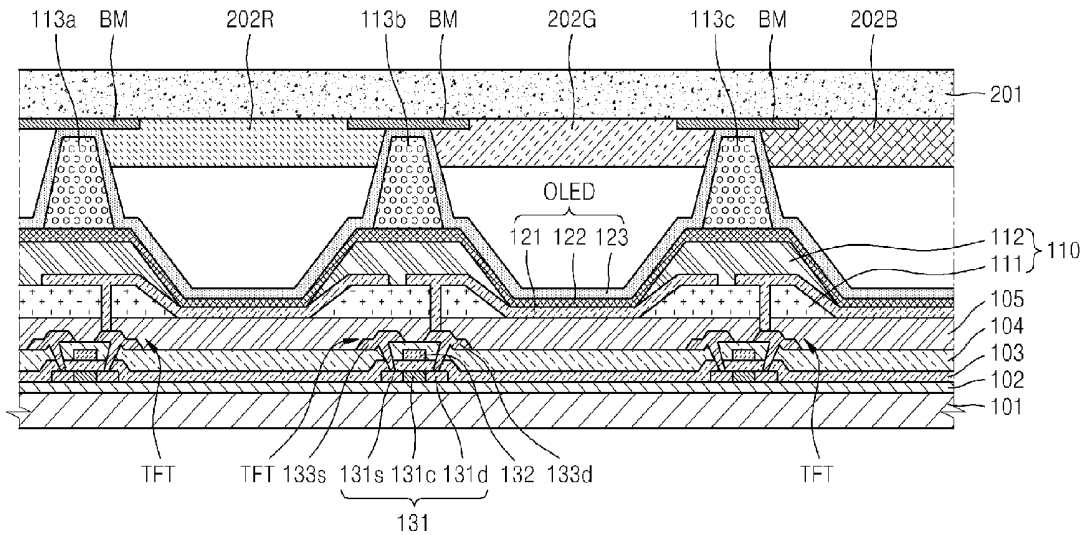

FIG. 2

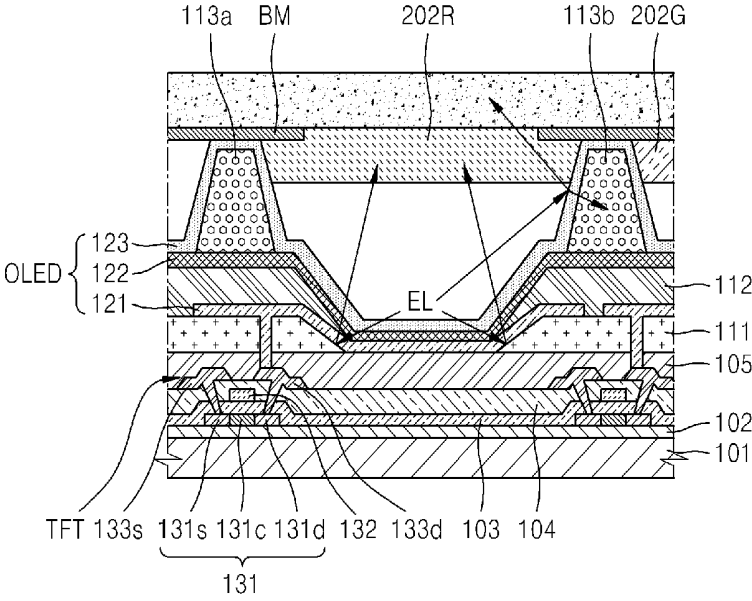
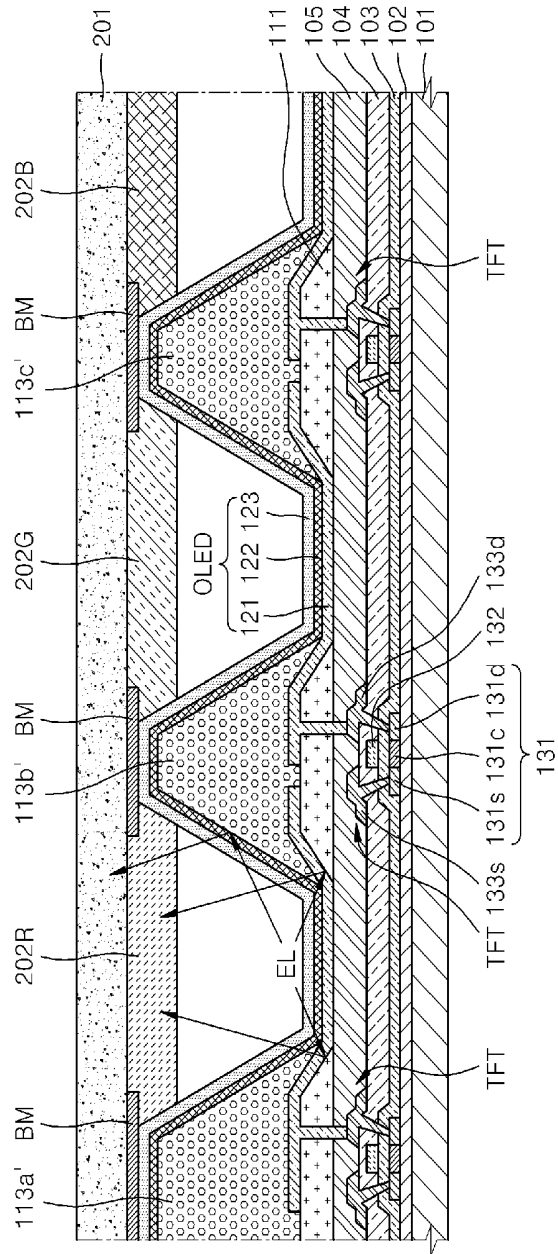

FIG. 3



ORGANIC WHITE LIGHT EMITTING DISPLAY APPARATUS

CROSS-REFERENCE TO RELATED APPLICATIONS

[0001] This application claims the benefit of Korean Patent Application No. 10-2013-0063075, filed on May 31, 2013, in the Korean Intellectual Property Office, the disclosure of which is incorporated herein in its entirety by reference.

BACKGROUND

[0002] 1. Field

[0003] The present embodiments relate to an organic white light emitting display apparatus.

[0004] 2. Description of the Related Technology

[0005] Flat display apparatuses such as a plasma display plane (PDP), liquid crystal display apparatuses, and organic electroluminescence display apparatuses are attracting considerable attention.

[0006] The liquid crystal display apparatus is not a self-luminous device, but a light-receiving device, and thus there is a limit in brightness, contrast, a vision angle, and forming a large size device. The PDP is a self-luminous device, but the PDP is heavier than other flat display apparatuses, consumption power is high, and the manufacturing method is complicated.

[0007] In contrast, the organic electroluminescence display apparatus is a self-luminous device and thus a superior vision angle and contrast are shown, and since a backlight is not necessary, a light and thin type is possible and less consumption power is used compared to other display apparatuses. Furthermore, a low DC voltage operation is possible, response speed is high, the temperature range for use is wide, the manufacturing method is simple and inexpensive, and it is resistant to external impacts.

[0008] In the organic electroluminescence display apparatus, one unit pixel for expressing natural color is composed of sub-pixels of red R, green G, and blue B, and the sub-pixels may include an organic light emitting layer that emits white light. When the organic electroluminescence display apparatus is a top emission type, a gap between the organic light emitting layer that emits light and a color filter is large compared to a bottom emission type, and thus there is a limit in implementing desired color.

SUMMARY

[0009] The present embodiments provide a top emission type organic white light emitting display apparatus.

[0010] According to an aspect of the present embodiments, there is provided an organic white light emitting display apparatus including: a first substrate including a first sub-pixel area, a second sub-pixel area, a third sub-pixel area, wherein an organic light emitting device (OLED) is formed in each sub-pixel area, the OLED includes a first electrode, a second electrode, and an organic white light emitting layer interposed between the first and second electrodes and emits white light; a second substrate facing the first substrate and including first, second, and third color filters of different colors formed on positions corresponding to the respective sub-pixel areas; and a partition wall formed on the first substrate, extending to an area between neighboring color filters among the color filters and partitioning the sub-pixel areas.

[0011] The second electrode of the OLED may be formed on the partition wall.

[0012] The second substrate may include a black matrix formed between the neighboring color filters.

[0013] The partition wall may contain a pigment of a color other than colors of color filters arranged at both sides on the basis of the partition wall.

[0014] A partition wall arranged between the first color filter and the second color filter may contain a pigment of the third color, a partition wall arranged between the second color filter and the third color filter may contain a pigment of the first color, and a partition wall arranged between the third color filter and the first color filter may contain a pigment of the second color.

[0015] The first color may be red, the second color may be green, and the third color may be blue.

[0016] The organic white light emitting display apparatus of claim 1 may further include: a thin film transistor (TFT) formed on the first substrate; a planarization layer formed on the TFT; a first pixel defined layer formed on the planarization layer and including an inclined surface and an opening that defines the sub-pixel area; and a second pixel defined layer formed on the first pixel defined layer, wherein a peripheral part of the first electrode of the OLED is formed on the inclined surface of the first pixel defined layer.

[0017] The partition wall may be formed on the second pixel defined layer.

[0018] The partition wall and the second pixel defined layer may be integrally formed.

[0019] The second pixel defined layer may cover the first electrode formed on the inclined surface of the first pixel defined layer.

[0020] According to another aspect of the present embodiments, there is provided an organic white light emitting display apparatus including: a first substrate including red, green, and blue sub-pixel areas; a second substrate facing the first substrate and including red, green, and blue color filters formed at positions corresponding to the sub-pixel areas; a pixel defined layer formed on the first substrate, the pixel defined layer defines the sub-pixel areas; a partition wall formed on the pixel defined layer, extending to an area between neighboring color filters among the color filters and partitioning the sub-pixel areas; a first electrode formed on the first substrate and positioned for each of the sub-pixel areas; an intermediate layer formed on the first electrode and including an organic white light emitting layer; and a second electrode formed on the intermediate layer and the partition wall.

[0021] The partition wall may contain a pigment of a color other than colors of color filters arranged at both sides on the basis of the partition wall.

[0022] A partition wall extended to an area between the red color filter and the green color filter may contain a blue pigment, a partition wall extended to an area between the green color filter and the blue color filter may contain a red pigment, and a partition wall extended to an area between the blue color filter and the red color filter may contain a green pigment.

[0023] The organic white light emitting display apparatus of claim 11 may further include: a thin film transistor (TFT) formed on the first substrate; a planarization layer formed on the TFT; a first pixel defined layer formed on the planarization layer and including an inclined surface and an opening that defines the sub-pixel area; and a second pixel defined layer

formed on the first pixel defined layer, wherein a peripheral part of the first electrode of an organic light emitting device is formed on the inclined surface of the first pixel defined layer.

[0024] The first electrode may include reflective metal.

[0025] The partition wall may be formed on the second pixel defined layer.

[0026] The partition wall and the second pixel defined layer may be integrally formed.

[0027] The second substrate may further include a black matrix formed in an area between the neighboring color filters.

[0028] An upper part of the partition wall may be arranged to correspond to the black matrix.

[0029] The second electrode may have translucency and reflexivity that reflects at least some of light, which is emitted toward the partition wall among white light emitted from the intermediate layer, toward the second substrate.

BRIEF DESCRIPTION OF THE DRAWINGS

[0030] The above and other features and advantages of the present embodiments will become more apparent by describing in detail example embodiments thereof with reference to the attached drawings in which:

[0031] FIG. 1 is a cross-sectional diagram schematically illustrating an organic white light emitting display apparatus according to an embodiment;

[0032] FIG. 2 is a cross-sectional diagram illustrating one sub-pixel area of FIG. 1; and

[0033] FIG. 3 is a cross-sectional diagram schematically illustrating an organic white light emitting display apparatus according to another embodiment.

DETAILED DESCRIPTION

[0034] As used herein, the term “and/or” includes any and all combinations of one or more of the associated listed items.

[0035] The present embodiments will now be described more fully with reference to the accompanying drawings, in which example embodiments are shown. The embodiments may, however, be embodied in many different forms and should not be construed as being limited to the embodiments set forth herein; rather, these embodiments are provided so that this disclosure will be thorough and complete, and will fully convey the concept of the embodiments to those skilled in the art. In the drawings, the thicknesses of layers and regions are exaggerated for clarity. Terms such as “including,” “having,” “consist of” may be intended to indicate a plurality of components unless the terms are used with the term “only.”

[0036] It will also be understood that when a layer is referred to as being “on” another layer or substrate, it can be directly on the other layer or substrate, or intervening layers may also be present. Like reference numerals in the drawings denote like elements, and thus their description will be omitted.

[0037] FIG. 1 is a cross-sectional diagram schematically illustrating an organic white light emitting display apparatus (hereinafter, referred to as “display apparatus”) according to an embodiment, and FIG. 2 is a cross-sectional diagram illustrating one sub-pixel area of FIG. 1.

[0038] A first substrate 101 includes a plurality of sub-pixel areas. For example, the first substrate 101 may include a first sub-pixel area (red), a second sub-pixel area (green), and a

third sub-pixel area (blue), and an organic light emitting device (OLED) that emits white light is formed in each sub-pixel area.

[0039] A second substrate 210 is arranged to face the first substrate 101, and the second substrate 201 includes color filters 202R, 202G, and 202B formed at positions corresponding to respective sub-pixel areas, and a black matrix formed between the color filters 202R, 202G, and 202B. The display apparatus according to an embodiment is a top emission type, and white light emitted from each sub-pixel area emits red light, green light, and blue light as the white light passes through the color filters 202R, 202G, and 202B formed on the second substrate 201.

[0040] Partition walls 113a, 113b, and 113c, which are extended to areas between neighboring color filters 202R, 202G, and 202B and partition the sub-pixel areas, are formed on the first substrate 101. The partition walls 113a, 113b, and 113c may be formed to cover one sub-pixel area entirely or partly.

[0041] Color purity at each sub-pixel area may be improved by the partition walls 113a, 113b, and 113c. As a comparative example of the present embodiments, a front-emitting display apparatus without the partition walls 113a, 113b, and 113c that partition respective sub-pixel areas will be described below.

[0042] In the display apparatus according to the comparative example of the present embodiments, it is assumed that power is supplied only to an OLED formed at a position corresponding to the green color filter 202G in order to view green light. In this case, there is a gap between the first substrate and the second substrate, and thus white light emitted from the OLED emits toward all directions. A part of the emitted light emits toward the red color filter 202R and the blue color filter 202B included in pixels adjacent to the green pixel. Hence, a user views red and blue light as well as green light, and thus it is impossible to display pure green light. Color purity of green is deteriorated.

[0043] However, according to an embodiment, the partition walls 113a, 113b, and 113c that partition adjacent sub-pixel areas are provided, and thus the mixture of colors other than the desired colors may be prevented.

[0044] Hereinafter, the structure of the display apparatus of the present embodiments will be described with reference to FIGS. 1 and 2.

[0045] The first substrate 101 may be made of glass or plastic. For example, the first substrate 101 may comprise an organic insulation material selected from a group composed of polyethersulphone (PES), polyacrylate (PAR), polyetherimide (PEI), polyethylenenaphthalate (PEN), polyethylene terephthalate (PET), polyphenylene sulphide (PPS), polyallylate, polyimide, polycarbonate (PC), cellulose triacetate (TAC), and cellulose acetate propionate (CAP) which are insulating organic matters.

[0046] The display apparatus according to the present embodiments includes a top emission type display apparatus, and thus the first substrate 101 may comprise one or more selected from a group composed of iron, chrome, manganese, nickel, titanium, molybdenum, stainless steel (SUS), Invar alloy, Inconel alloy, and Kovar alloy, but the present embodiments are not limited thereto.

[0047] A buffer layer 102 may be formed on the first substrate 101. The buffer layer 102 may comprise one of a silicon oxide film, a silicon nitride film and multiple films thereof.

[0048] A thin film transistor (TFT) is formed on the buffer layer **102**. At least one TFT is formed for each pixel and is electrically connected to the OLED to operate as a driving circuit unit. The TFT broadly includes an active layer **131**, a gate electrode **132**, a source electrode **133s**, and a drain electrode **133d**.

[0049] The active layer **131** may comprise an inorganic semiconductor such as amorphous silicon or poly silicon, or an organic semiconductor, and includes a source area **131s**, a drain area **131d**, and a channel area **131c**. The source and drain areas **131s** and **131d** may be formed by doping impurities to the active layer **131** comprising amorphous silicon or poly silicon. If doped by group III elements such as boron B, a p-type semiconductor may be formed, and if doped by group V elements such as nitrogen N, an n-type semiconductor may be formed.

[0050] A gate insulation layer **103** is formed on the upper part of the active layer **131**, and the gate electrode **132** is formed on a predetermined area of the upper part of the gate insulation layer **103**. The gate insulation layer **103** is used to insulate the active layer **131** and the gate electrode **132**, and may comprise organic material or inorganic material such as silicon oxide and silicon nitride.

[0051] The gate electrode **132** may comprise metal such as Au, Ag, Cu, Ni, Pt, Pd, Al, and Mo, or a metal alloy such as an Al:Nd alloy and a Mo:W alloy, but the present embodiments are not limited thereto, and various materials may be used in consideration of coherence with an adjacent layer, flatness of a stacked layer, electric resistance, formability, etc.

[0052] An interlayer insulation film **104** including a contact hole is formed on the upper part of the gate electrode **132**. The source electrode **133s** and the drain electrode **133d** are formed to contact the source area and the drain area of each active layer **131** through the contact hole. The source electrode **133s** and the drain electrode **133d** may comprise metal such as Au, Ag, Cu, Ni, Pt, Pd, Al, and Mo, or a metal alloy such as an Al:Nd alloy and a Mo:W alloy, but the present embodiments are not limited thereto.

[0053] The formed TFT is covered and protected by a planarization layer **105**. The planarization layer **105** may comprise an inorganic insulation film and/or an organic insulation film.

[0054] Thereafter, a pixel defined layer **110** made of insulating materials is formed on the planarization layer. The OLED including a first electrode **121**, an intermediate layer **122**, and a second electrode **123** is formed on the sub-pixel area defined by the pixel-defined layer **110**. Here, the first electrode, e.g., a peripheral part of the first electrode, may include an inclined surface so that light, which is emitted in a horizontal direction, e.g., a right and left direction of the display apparatus of FIG. 2, among white light emitted from the intermediate layer **122**, may be reflected to be emitted toward the second substrate **201**.

[0055] The pixel defined layer may include a first pixel defined layer **111** and a second pixel defined layer **112** formed on the first pixel defined layer **111**, and the first electrode **121** may be formed between the first pixel defined layer **111** and the second pixel defined layer **112**. The first pixel defined layer **111** and the second pixel defined layer **112** may comprise one or more organic materials selected from a group composed of polyimide, polyamide, acrylic resin, benzocyclobutene, and phenol resin.

[0056] First, an opening is formed so that the peripheral part of the first pixel defined layer **111** may have an inclined

surface, and the first electrode **121** is formed on the opening and the inclined surface of the first pixel defined layer **111**. The first electrode **121** may be electrically connected to the drain electrode **133d** of the TFT through the contact hole formed at the edge of the first pixel defined layer **111**.

[0057] As illustrated in FIG. 2, as the peripheral part of the first electrode **121** is formed on the inclined surface of the first pixel defined layer **111**, the first electrode **121** may also include an inclined surface having a predetermined angle toward the first substrate **101**. The first electrode is a reflective electrode, and may contain reflective metal comprising Ag, Mg, Al, Pt, Pd, Au, Ni, Nd, Ir, Cr, or an alloy thereof, etc.

[0058] Hence, light, which is emitted in a horizontal direction, e.g., toward the first pixel defined layer **111**, among white light emitted from the intermediate layer **122**, is reflected to be emitted toward the second substrate **201**, and thus optical efficiency may be improved.

[0059] The second pixel defined layer **112** including an opening, which has substantially the same shape as that of the opening of the first pixel defined layer, is formed on the first electrode **121**, and the intermediate layer **122** including an organic white light emitting layer is formed on the second pixel defined layer **112**.

[0060] When the organic white light emitting layer of the intermediate layer **122** comprises low molecular organic materials, a hole transport layer, a hole injection layer, an electron transport layer, an electron injection layer, etc. may be stacked. Furthermore, various other layers may be stacked as necessary. Alternatively, when the organic white light emitting layer of the intermediate layer **122** comprises high molecular organic materials, only the hole transport layer may be included on the basis of the organic white light emitting layer.

[0061] The partition walls **113a**, **113b**, and **113c** are formed on the second pixel defined layer **112**, and as described above, the partition walls **113a**, **113b**, and **113c** are interposed between areas between the color filters **202R**, **202G**, and **202B**, e.g., neighboring sub-pixel areas, so as to spatially separate the pixels and prevent light emitted from each sub-pixel area from being emitted toward adjacent sub-pixel areas. The partition walls **113a**, **113b**, and **113c** may comprise one or organic materials selected from a group composed of polyimide, polyamide, acrylic resin, benzocyclobutene, and phenol resin.

[0062] A second electrode **123** is formed on the partition walls **113a**, **113b**, and **113c**. The second electrode **123** is a light-transmitting electrode and may comprise a transparent conductive layer comprising ITO, IZO, ZnO or In₂O₃, or thin metal such as a Mg:Ag alloy. In particular, when the second electrode **123** comprises a thin Mg:Ag alloy, the second electrode **123** may have translucency and reflect light, and thus as illustrated in FIG. 2, part of light emitted toward the partition walls **113a**, **113b**, and **113c** among light emitted from the organic white light emitting layer is reflected in the second electrode **123** to be emitted toward the color filters **202R**, **202G**, and **202B**, thereby enhancing light collecting efficiency.

[0063] A part of the remaining light that is emitted toward the partition walls **113a**, **113b**, and **113c** among light emitted from the organic white light emitting layer is not reflected by the second electrode **123**, and may be absorbed in the partition walls **113a**, **113b**, and **113c**. Here, in order to block light that fails to be absorbed in the partition walls **113a**, **113b**, and **113c** and is transmitted among light emitted toward the par-

tion walls **113a**, **113b**, and **113c**, the partition walls **113a**, **113b**, and **113c** may include pigments of a color other than the color of the color filters **202R**, **202G**, and **202B** arranged at both sides on the basis of the partition walls **113a**, **113b**, and **113c**. For example, the partition wall **113b** arranged between the red color filter **202R** and the green color filter **202G** may contain blue pigments, the partition wall **113c** arranged between the green color filter **202G** and the blue color filter **202B** may contain red pigments, and the partition wall **113a** arranged between the blue color filter **202B** and the red color filter **202R** may contain green pigments.

[0064] For example, as illustrated in FIG. 2, light that is emitted toward the partition wall **113b** among white light emitted from the intermediate layer **122** corresponding to the red sub-pixel area may be mostly absorbed in the partition wall **113b**, but light that fails to be absorbed in the partition wall **113b** may pass through the partition wall **113b** and become blue light. However, according to an embodiment, the color filters **202R** and **202G** arranged at both sides of the partition wall **113b** do not transmit blue light, and thus the blue light may not be emitted toward the external side.

[0065] Likewise, since respective partition walls **113a**, **113b**, and **113c** contain pigments, a little amount of light that fails to be absorbed in the partition walls **113a**, **113b**, and **113c** may be prevented from being viewed from the external side, and thus light having a color other than colors of the sub-pixel areas is prevented from being emitted to an external side and color purity at each sub-pixel area may be enhanced.

[0066] FIG. 3 is a cross-sectional diagram schematically illustrating an organic white light emitting display apparatus (hereinafter, referred to as "display apparatus") according to another embodiment.

[0067] The display apparatus according to the present embodiment includes a first substrate **101** including a plurality of sub-pixel areas, an organic light emitting device (OLED) formed for each sub-pixel area, and a second substrate **201** including red, green, and blue color filters **202R**, **202G**, and **202B** formed on positions corresponding to respective sub-pixel areas.

[0068] Furthermore, partition walls **113a'**, **113b'**, and **113c'** are extended toward areas between neighboring color filters **202R**, **202G**, and **202B**, the second electrode **123** is formed on the partition walls **113a'**, **113b'**, and **113c'**, the first electrode **121** is formed on the first pixel defined layer **111** having an inclined surface so that the peripheral part of the first electrode **121** includes an inclined surface, and the partition walls **113a'**, **113b'**, and **113c'** contain pigments as described with reference to FIGS. 1 and 2.

[0069] The description will focus on the differences with the description of FIGS. 1 and 2.

[0070] In the display apparatus according to the present embodiment, the second pixel defined layer and the partition walls **113a'**, **113b'**, and **113c'** may be integrally formed. In this case, the intermediate layer **122** and the second electrode **123** may be formed on the partition walls **113a'**, **113b'**, and **113c'**.

[0071] First, an opening is formed so that the peripheral part of the first pixel defined layer **111** may have an inclined surface, and the first electrode **121** is formed on the opening and the inclined surface of the first pixel defined layer **111**. The peripheral part of the first electrode **121** is formed on the inclined surface of the first pixel defined layer **111**, and thus light, which is emitted in a horizontal direction, e.g., toward the first pixel defined layer **111** among white light emitted from the intermediate layer **122**, may be reflected in the

inclined surface of the first electrode **121** to be emitted toward the second substrate **201**, as described with reference to FIG. 2.

[0072] Next, the partition walls **113a'**, **113b'**, and **113c'** extended toward the areas between the color filters **202R**, **202G**, and **202B** are formed. The partition walls **113a'**, **113b'**, and **113c'** are interposed between the neighboring sub-pixel areas to spatially separate the pixels and prevent light emitted from each sub-pixel area from being emitted toward the adjacent sub-pixel areas. The partition walls **113a'**, **113b'**, and **113c'** may comprise one or more organic material selected from a group composed of polyimide, polyamide, acrylic resin, benzocyclobutene, and phenol resin. Thereafter, the intermediate layer **122** and the second electrode **123** are formed on the partition walls **113a'**, **113b'**, and **113c'**.

[0073] Furthermore, some of light emitted from the OLED is reflected to be emitted toward the color filters **202R**, **202G**, and **202B** by the second electrode **123** formed on the partition walls **113a'**, **113b'**, and **113c'**, and the partition walls **113a'**, **113b'**, and **113c'** contain pigments in order to prevent light that fails to be absorbed in the partition walls **113a'**, **113b'**, and **113c'** and transmits the partition walls **113a'**, **113b'**, and **113c'** from being viewed from the external side, as described above.

[0074] According to an embodiment, partition walls that entirely or partially surround respective sub-pixels are formed, and thus light emitted from one sub-pixel may be prevented from entering an adjacent sub-pixel, light may be prevented from being emitted through other sub-pixels when one sub-pixel is turned on, and color purity of light emitted from each sub-pixel area may be enhanced.

[0075] Furthermore, the first electrode is formed to have an inclined surface, and thus light collecting efficiency may be enhanced.

[0076] While the present embodiments have been particularly shown and described with reference to example embodiments thereof, it will be understood by those of ordinary skill in the art that various changes in form and details may be made therein without departing from the spirit and scope of the present embodiments as defined by the following claims.

What is claimed is:

1. An organic white light emitting display apparatus comprising:
 - a first substrate including a first sub-pixel area, a second sub-pixel area, a third sub-pixel area, wherein an organic light emitting device (OLED) is formed in each sub-pixel area, the OLED includes a first electrode, a second electrode, and an organic white light emitting layer interposed between the first and second electrodes configured to emit white light;
 - a second substrate facing the first substrate and including first, second, and third color filters of different colors formed on positions corresponding to the respective sub-pixel areas; and
 - a partition wall formed on the first substrate, extending to an area between neighboring color filters among the color filters and partitioning the sub-pixel areas.
2. The organic white light emitting display apparatus of claim 1, wherein the second electrode of the OLED is formed on the partition wall.
3. The organic white light emitting display apparatus of claim 1, wherein the second substrate includes a black matrix formed between the neighboring color filters.
4. The organic white light emitting display apparatus of claim 1, wherein the partition wall comprises a pigment of a

color other than colors of color filters arranged at both sides on the basis of the partition wall.

5. The organic white light emitting display apparatus of claim 4, wherein a partition wall arranged between the first color filter and the second color filter comprises a pigment of the third color, a partition wall arranged between the second color filter and the third color filter comprises a pigment of the first color, and a partition wall arranged between the third color filter and the first color filter comprises a pigment of the second color.

6. The organic white light emitting display apparatus of claim 1, wherein the first color is red, the second color is green, and the third color is blue.

7. The organic white light emitting display apparatus of claim 1, further comprising:

a thin film transistor (TFT) formed on the first substrate;
 a planarization layer formed on the TFT;
 a first pixel defined layer formed on the planarization layer and including an inclined surface and an opening that defines the sub-pixel area; and
 a second pixel defined layer formed on the first pixel defined layer,
 wherein a peripheral part of the first electrode of the OLED is formed on the inclined surface of the first pixel defined layer.

8. The organic white light emitting display apparatus of claim 7, wherein the partition wall is formed on the second pixel defined layer.

9. The organic white light emitting display apparatus of claim 8, wherein the partition wall and the second pixel defined layer are integrally formed.

10. The organic white light emitting display apparatus of claim 7, wherein the second pixel defined layer covers the first electrode formed on the inclined surface of the first pixel defined layer.

11. An organic white light emitting display apparatus comprising:

a first substrate including red, green, and blue sub-pixel areas;
 a second substrate facing the first substrate and including red, green, and blue color filters formed at positions corresponding to the sub-pixel areas;
 a pixel defined layer formed on the first substrate, wherein the pixel defined layer defines the sub-pixel areas;
 a partition wall formed on the pixel defined layer, extending to an area between neighboring color filters among the color filters and partitioning the sub-pixel areas;
 a first electrode formed on the first substrate and positioned for each of the sub-pixel areas;

an intermediate layer formed on the first electrode and including an organic white light emitting layer; and
 a second electrode formed on the intermediate layer and the partition wall.

12. The organic white light emitting display apparatus of claim 11, wherein the partition wall comprises a pigment of a color other than colors of color filters arranged at both sides on the basis of the partition wall.

13. The organic white light emitting display apparatus of claim 11, wherein a partition wall extended to an area between the red color filter and the green color filter comprises a blue pigment, a partition wall extended to an area between the green color filter and the blue color filter comprises a red pigment, and a partition wall extended to an area between the blue color filter and the red color filter comprises a green pigment.

14. The organic white light emitting display apparatus of claim 11, further comprising:

a thin film transistor (TFT) formed on the first substrate;
 a planarization layer formed on the TFT;
 a first pixel defined layer formed on the planarization layer and including an inclined surface and an opening that defines the sub-pixel area; and
 a second pixel defined layer formed on the first pixel defined layer,
 wherein a peripheral part of the first electrode of an organic light emitting device is formed on the inclined surface of the first pixel defined layer.

15. The organic white light emitting display apparatus of claim 14, wherein the first electrode includes reflective metal.

16. The organic white light emitting display apparatus of claim 14, wherein the partition wall is formed on the second pixel defined layer.

17. The organic white light emitting display apparatus of claim 16, wherein the partition wall and the second pixel defined layer are integrally formed.

18. The organic white light emitting display apparatus of claim 11, wherein the second substrate further includes a black matrix formed in an area between the neighboring color filters.

19. The organic white light emitting display apparatus of claim 18, wherein an upper part of the partition wall is arranged to correspond to the black matrix.

20. The organic white light emitting display apparatus of claim 11, wherein the second electrode has translucency and reflexivity that reflects at least some light, which is emitted toward the partition wall among white light emitted from the intermediate layer, toward the second substrate.

* * * * *

专利名称(译)	有机白光发光显示装置		
公开(公告)号	US20140353630A1	公开(公告)日	2014-12-04
申请号	US14/222417	申请日	2014-03-21
[标]申请(专利权)人(译)	三星显示有限公司		
申请(专利权)人(译)	三星DISPLAY CO. , LTD.		
当前申请(专利权)人(译)	三星DISPLAY CO. , LTD.		
[标]发明人	BAEK SOO MIN KIM MIN WOO KIM IL NAM LIM JAE IK		
发明人	BAEK, SOO-MIN KIM, MIN-WOO KIM, IL-NAM LIM, JAE-IK		
IPC分类号	H01L27/32		
CPC分类号	H01L27/3262 H01L27/3211 H01L27/322 H01L27/3246 H01L51/525 H01L51/5262 H01L27/3218 H01L27/3274 H01L51/50 H01L51/5036 H01L27/3276		
优先权	1020130063075 2013-05-31 KR		
其他公开文献	US9419242		
外部链接	Espacenet USPTO		

摘要(译)

公开了一种有机白光发射显示装置。有机白光发光装置包括：第一基板，包括第一子像素区域，第二子像素区域，第三子像素区域；以及有机发光装置（OLED），其包括第一电极，第二电极和插入在第一和第二电极之间的有机白光发射层，并为各个子像素区域发射白光，第二基板包括在对应于各个子区域的位置上形成的不同颜色的第一，第二和第三滤色器像素区域，第二基板布置成面对第一基板，以及分隔壁，其延伸到滤色器中的相邻滤色器之间的区域并分隔子像素区域，分隔壁形成在第一基板上。

